

TANDEM element sa potpunim izvlačenjem sa TIP-ON – 560H



Web kod – unesite ili kliknite u konfiguratoru proizvoda

DQEEHC

Planiranje

Potreban prostor u korpusu

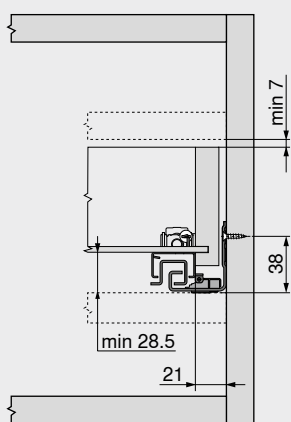

Fioka | unutrašnja fioka

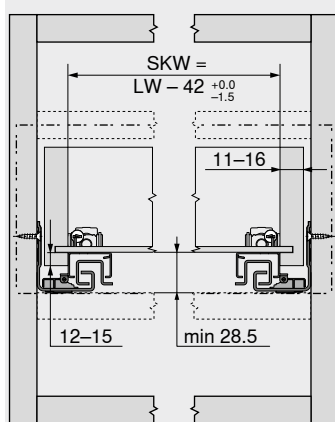

SKW Unutrašnja širina fioke
LW Unutrašnja širina korpusa

Fioka

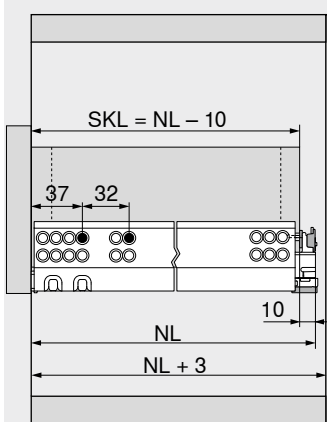

SKL Dužina fioke
NL Nominalna dužina

Unutrašnja fioka

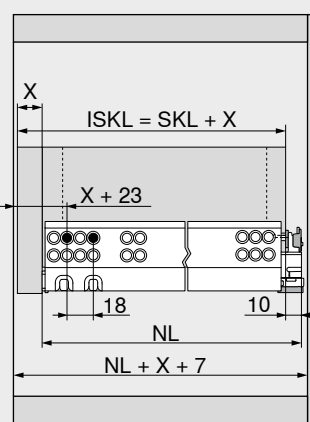

ISKL Unutrašnja dužina fioke
SKL Dužina fioke
NL Nominalna dužina
X Debljina fronta

Obrada fioka

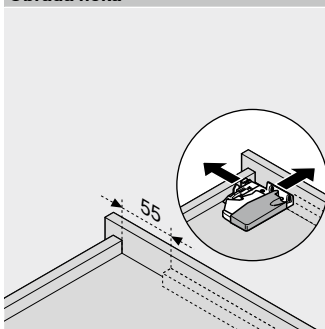

Koristiti šablon otvora T65.1000.02

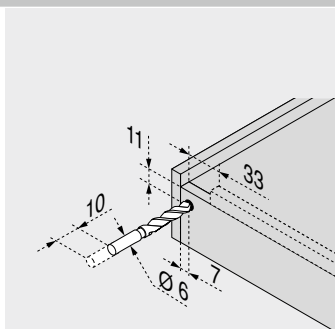

Koristiti šablon otvora T65.1000.02

Oblast aktiviranja

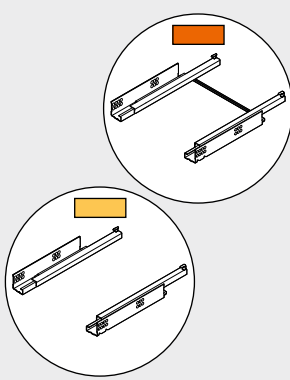
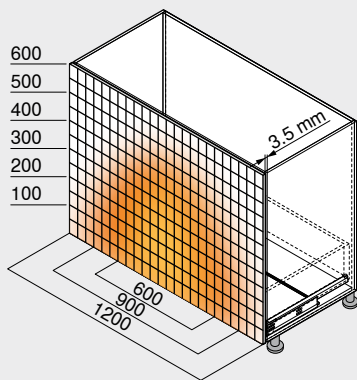

Primer za 560H – 30 kg, nominalna dužina NL 500 mm, mnogostrana fioka, sa sinhronizacijom

Napomene o stranama

Pregled	507
TANDEM	430
CABLOXX	594
Pribor	452
Pričvršćivanje vodica	528
Blum usluge	602
Ostale tehničke informacije	708

Montaža, demontaža i podešavanje

Short-URL
www.blum.com/a420

